

GenX Overfill Prevention Valve (OPV)

The Clay & Bailey GenX 01228 Overfill Prevention Valve (OPV) is designed for a pressure fill application to prevent tank overfills by stopping product delivery when a pre-set liquid level is reached. The valve installs through 4" SCH 40 pipe nipple or on the top of spill container. Connects to either 2" or 3" fill piping.



Achieves maximum product level in shallow tanks.

- Adjusting float height is easy, no tools required.
- The valve can be set to the desired 90%, 95% or any other shut-off level providing a wide adjustment range of over 5" in 3/8" increments.
- Provides positive shut-off for low leak and visual confirmation via delivery hose light shock.
- Provides accurate liquid level shut-off in foaming fuels, such as diesel. Weighted float cuts through the fuel foam and shuts off at a true liquid level.
- Allows pressure relief in the fill line after OPV closes.
- Delivers full product flow up to shut-off for reduced fill time.
- Accepts fuel delivery up to 100 psi. The minimum operating pressure is 5 psi.
- 2" telescopic tube drop tube, recommended for taller tanks, consists of inner tube nested in outer tube. The drop tube threads directly on the valve body and extends to full length via gravity.
- Alternatively, 2" NPT SCH 40 pipe threads directly on the valve body serving as a drop tube for shorter tanks or may use multiple pipe sections connected with standard 2" coupling for taller tanks.
- Optional diffuser reduces diesel foaming inside the tank and reduces disturbing the sediment.
- Available optional test mechanism.
- For the use with clean liquids only.
- Optional 01228-03-4432 reducer bushing allows direct connection to 3" piping using 01228-03-3502 3X4 Threaded Collar.
- 01228-03-4415 adaptor allows connection to 3" camlock.

Models:

- 01228-03-4500 GenX Valve only (without fill or drop pipe)
- 01228-03-46XXYY GenX with 2" Camlock fill connection
- 01228-03-47XXYY GenX with 2" NPT Thread fill connection
- 01228-03-48XXYY GenX with 3" NPT Thread fill connection
- 01228-03-4410 Diffuser (used with 2" SCH 40 drop pipe)
- 01228-03-4432 3" to 2" NPT Reducer Bushing (used with 01228-03-3502 3X4 Threaded Collar)
- 01228-03-4899 3X4 Threaded Collar with 3"X2" NPT Reducer Bushing to directly connect to 3" piping
- 01228-03-3053 3" NPT to 3" Camlock Adaptor

(XX) – Fill Pipe Length

(YY) – Drop Tube Length

(T) – Testable option (at the end of the part number)

Adjusting float height and shut-off level is easy, fast and convenient. Two float halves are held together with stretchable O-ring. Simply, split float halves apart and slide float up or down to desired shut-off liquid level. Let go off halves and the float will lock into place at new shut-off level.

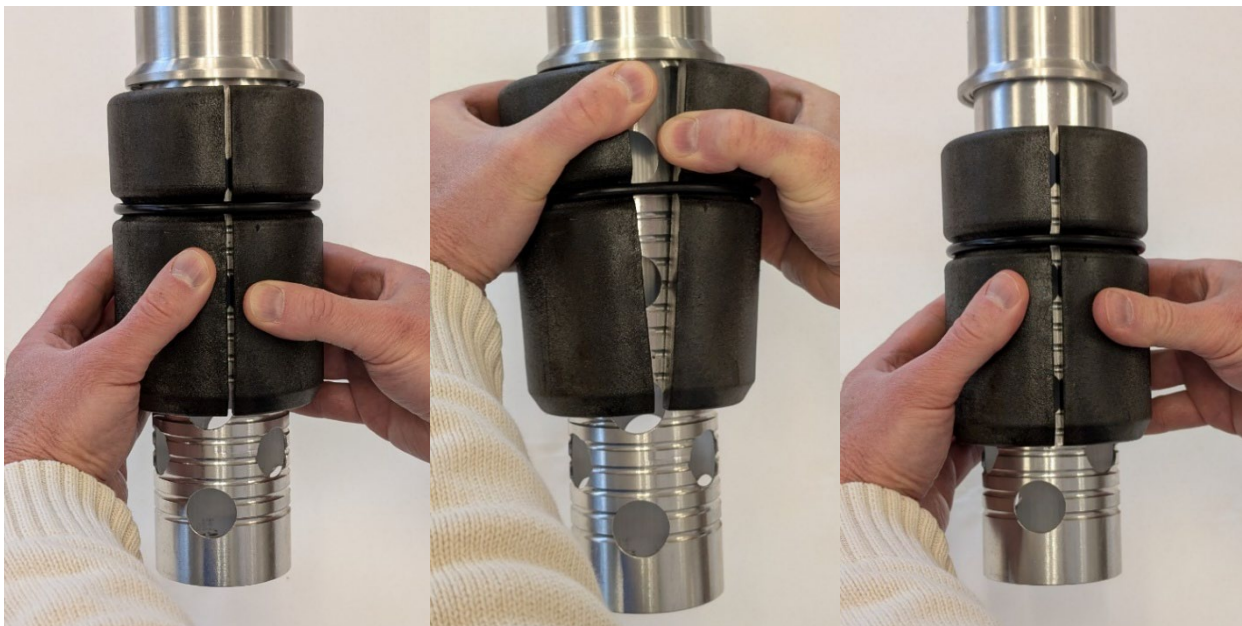



GenX OPV Flow Curve

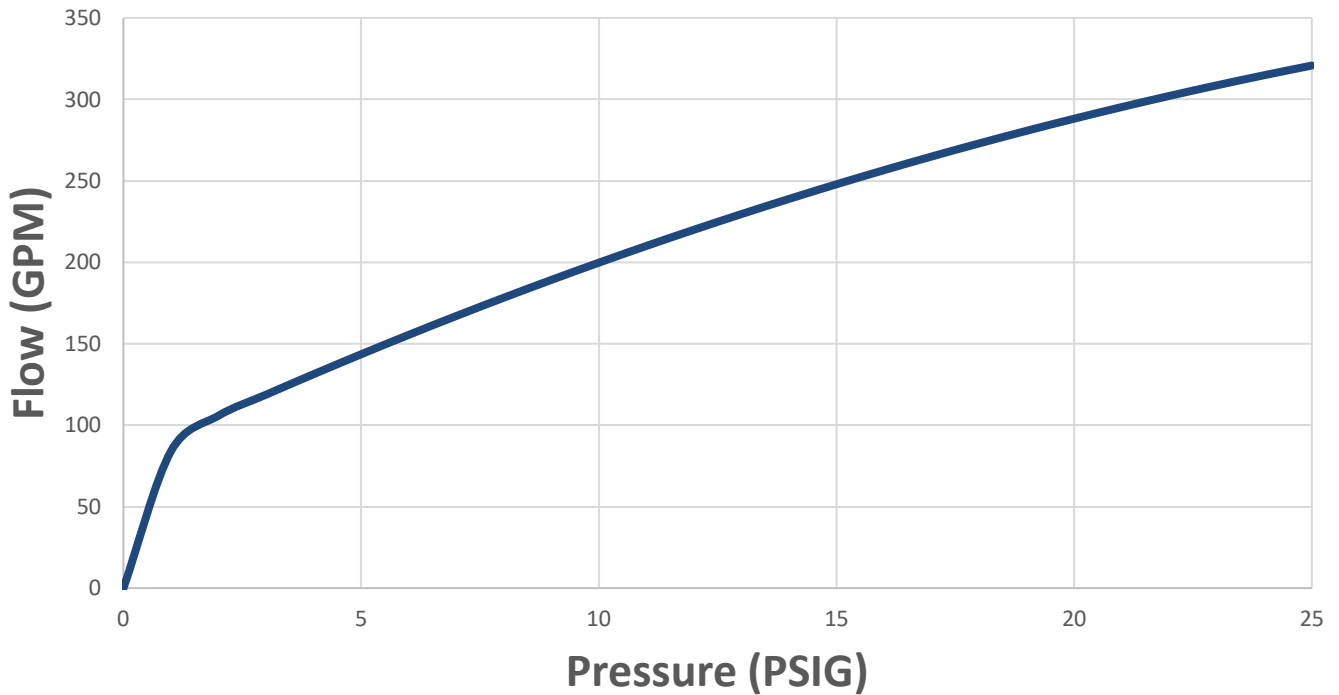

Code Compliance

Underwriters Laboratories Inc. ANSI/CAN/UL/ULC 2583 Listed;
Florida DEP EQ-1027; Petroleum Equipment Institute PEI RP200, PEI RP600;
National Fire Protection Agency NFPA 30, NFPA 30A

Please Complete This Table:					
Customer:					
OPV Model:	01228-03-46XXYY	01228-03-47XXYY	01228-03-48XXYY	Testable Option	
Quantity (EA):					
Tank Shape:	Rectangular	Round			
Orientation:	Horizontal	Vertical			
Primary Tank:	Height (inch)	Diameter (inch)			
Riser Height, Total from Primary Tank (inch):					
Percentage Fill, 90% or 95% typical (%):					
Accessories					
Telescopic Drop Tube					
Diffuser					
3" to 2" NPT Reducer Bushing					
3" Camlock to 3" NPT Adaptor					

Models:

- 01228-03-46XXYY, GenX with 2" Camlock fill connection
- 01228-03-47XXYY, GenX with 2" NPT Thread fill connection
- 01228-03-48XXYY, GenX with 3" NPT Thread fill connection
- 01228-03-4410, Diffuser (used with 2" SCH 40 drop pipe)
- 01228-03-4432, 3" to 2" NPT Reducer Bushing (used with 01228-03-3502 3X4 Threaded Collar)
- 01228-03-4899, 3X4 Threaded Collar with 3"X2" NPT Reducer Bushing to directly connect to 3" piping
- 01228-03-3053, 3" NPT to 3" Camlock Adaptor

(XX) – Fill Pipe Length

(YY) – Drop Tube Length

(T) – Testable option (at the end of the part number)

(TS) – Telescopic Drop Tube option (at the end of the part number)

(TTS) – Testable with Telescopic Drop Tube option (at the end of the part number)

★ This OPV Requires 4" Fill Opening in a Tank

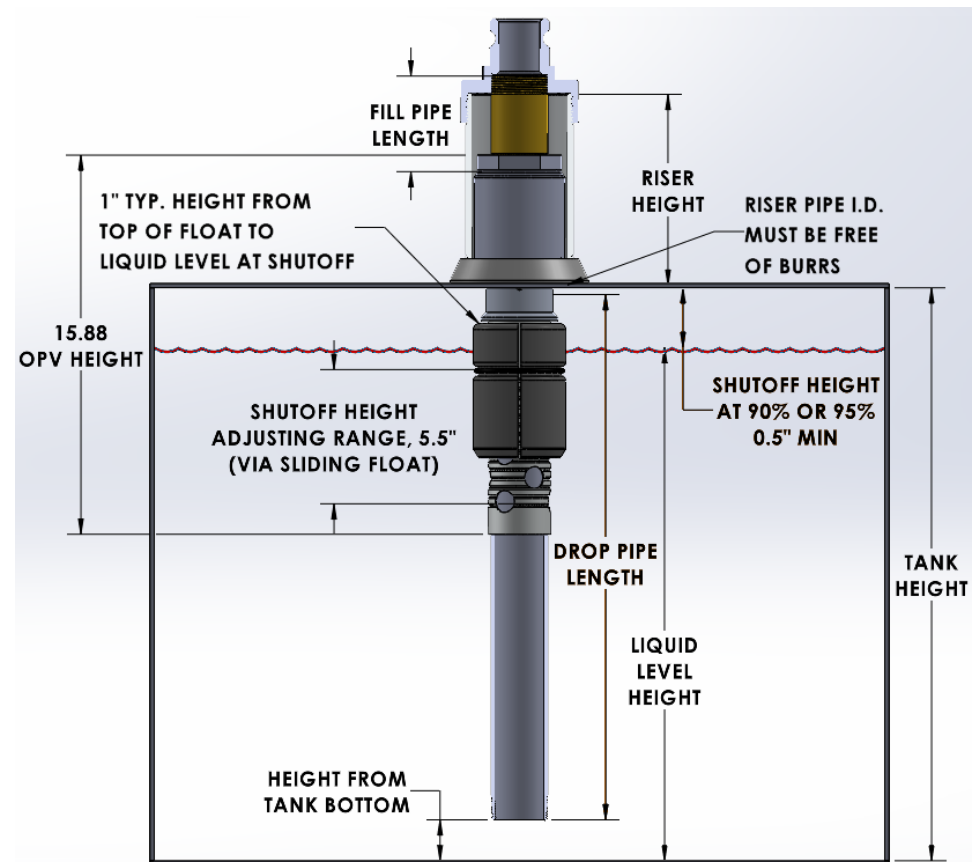

U.S. Patent No. 12,392,421

06/2026

6401 E. 40th St., Kansas City, Mo. 64129 • 1-800-821-6583 • F: 816-924-3903 • www.claybailey.com