



Instructions are for various models, please make sure you are following instructions for the correct part number.

Installation and Operation Instructions for the GenX 2" 1228-03-5600 model Overfill Prevention Valve:

CAUTION!

IMPORTANT INFORMATION – FOLLOW ALL INSTRUCTIONS

Read instructions carefully and follow the installation steps and operating procedures!

Failure to follow any of the warnings and instructions could result in a hazardous spill, and consequently in environmental contamination, property damage, fire, explosion, serious injury or death. The GenX series valves are designed for liquid tight fill operation and must be used with proper connections. Failure to properly connect or disconnect the delivery hose will result in a dangerous situation.

Warnings!

- 1. Fire Hazard – Extremely dangerous situation including serious injury or death could result from spilled liquids.**
2. Any modification to this valve that does not follow these instructions will void the product warranty.
3. The valve shall be used with clean liquid only. Contamination suspended in the liquid may cause the valve to malfunction.
4. Minimum operating pressure is 5 psi.

Clay & Bailey Mfg. Co.

Fact Sheet



A CENTURY'S WORTH OF INNOVATION

5. Maximum fill pressure is 100 psi.
6. This valve shall not be the only overfill prevention system in a tank. The operator shall continuously monitor the tank level to prevent any spillage even with a properly functioning valve.
7. This valve is to be used with a closed fill, liquid tight connection only.
8. All delivery system fill lines, valves and devices must function properly and be correctly set prior to filling.
9. Install in accordance with all applicable local, state, and federal codes.
10. For your safety, it is important to follow applicable local, state, federal and/or OSHA rules for working around storage tank and piping area. Always use all required personal protective equipment.
11. The tank could be under pressure. Vapor could escape from tank piping, vents, valves or fittings during installation and catch fire or cause an explosion. Do not use hot tools or open flame, eliminate sparks or any source of ignition when working on valves and around tanks.
12. Fill points shall be properly labeled to identify the handled product according to all applicable codes.
13. **When not filling, install either a camlock cap or threaded cap on the top of the collar or fill connection to protect valve internals from contaminants and exposure to environmental elements. The only time when the cap is removed is during filling.**
14. **Do not drop the valve as this could cause damage making it unable to operate properly.**

Warnings!

Attempting to disconnect the hose coupler with pressure in the line could result in the release of product!

CAUTION!

**This valve is to be used with a closed fill, liquid tight connection only.
Do not fill with a regular nozzle, splash back will occur.**



The GenX Overfill Prevention Valve (OPV) is installed at the fill port of a storage tank. Designed for a tight fill application, the valve prevents tank overfills by closing product delivery when the liquid level reaches a pre-set level (typically 90%-95% full). The valve threads directly on the 2" SCH 40 pipe nipple (riser) or on the top of spill container.

Installation

1. **Use all appropriate Personal Protective Equipment (PPE) before doing the job.**
2. Remove from packaging carefully to prevent damage to the valve. Check the valve for any shipping damage. The valve is shipped with 12" long piece of tubing that should be field cut to size based on tank dimensions and desired shut-off level. If any damage is found contact the manufacturer.
3. Record the serial number stamp on the side of the valve for future reference.
4. The valve is shipped fully assembled, however, the tubing is shipped loose since it is field cut to size. Follow the instructions from "Field Setup" to determine the tubing length. After tubing is cut and flared, attach the tubing via flared fitting nuts to the valve body on one end and diffuser/float assembly on another end. The float and the piston should move freely. Turn the valve upside down. Confirm that the float and the piston moved to the shut position. Set the valve upright, the float and the piston should move back to the open position. This is to ensure there is no binding on moving parts of the valve.
5. Inspect the inside of the riser pipe on the tank or spill containment box for burrs and any obstruction that may interfere with the valve installation or cause damage to the valve during installation. **Inside of riser pipe must be free of burrs.**
6. Apply fuel compatible thread sealant on male threads only to reduce the probability of sealant reaching the valve internals. Use of excessive thread sealant may cause the valve to malfunction.
7. Guide the valve assembly and float through the 2" NPT SCH 40 tank riser. **Do not force the valve through the opening. Be careful not to damage the float or threads.**
8. Thread the valve onto the riser by hand tightening first. Then use a strap wrench



and apply the correct number of wrench makeup turns to tighten the valve assembly to the riser pipe.

Be careful not to cross thread! Use a strap wrench only. Do not apply the wrench jaws directly to the valve body to avoid crushing the valve! This may damage the valve and cause malfunction. Do not overtighten! Refer to the following table for the correct number of makeup turns.

NPT Thread Size	Number of Wrench Makeup Turns
2"	1.5
3"	2.5
4"	3.0

Hand tighten before applying the appropriate number of the wrench makeup turns.

Due to variability of the thread form a tolerance of ± 1 turn is allowed.

Overtightening may likely cause thread damage.

GenX 2" OPV Field Setup

Follow "GenX 2" OPV Installation Instructions" at the end of this document.

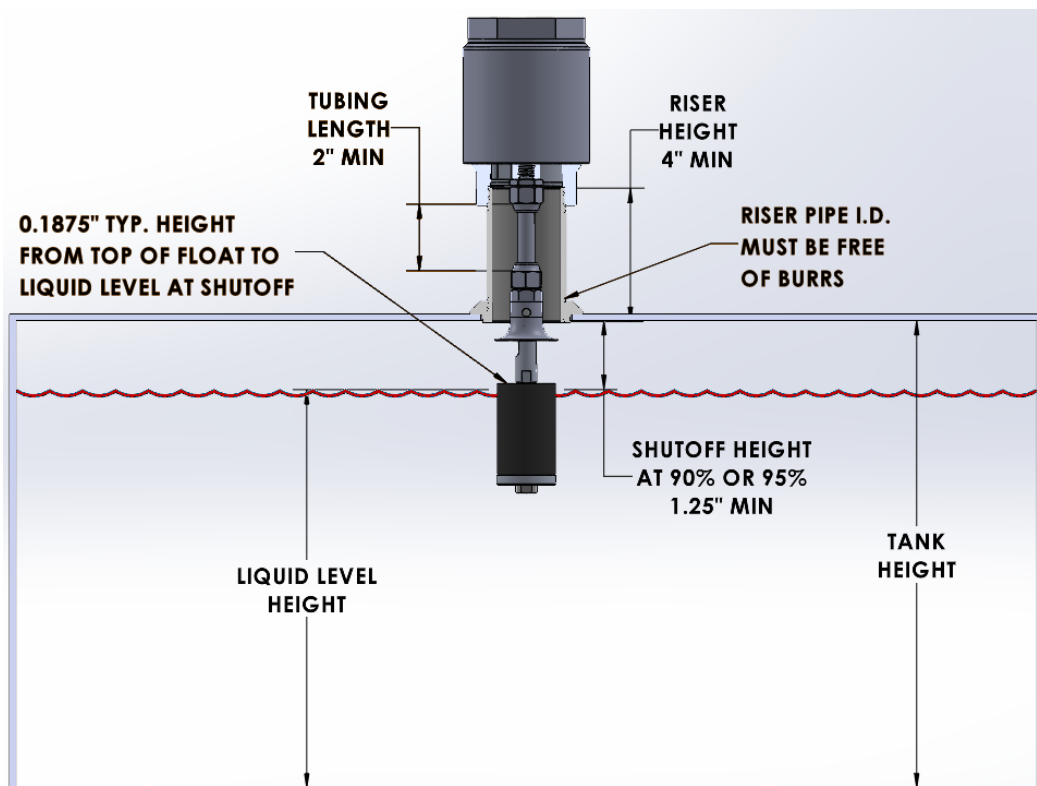

Clay & Bailey Mfg. Co.

Fact Sheet



A CENTURY'S WORTH OF INNOVATION

Models:

- 01228-03-5600 GenX 2" OPV with 12" long piece of tubing
(field cut to size based on tank dimensions)

Before Filling

1. Ensure that the bypass valve on the transport pump is set and working properly.
2. Do not exceed 100 psi delivery pressure.
3. Inspect delivery hose and fittings for wear, damage and leaks.
4. A dry break coupling or camlock type coupling is required for delivery.
5. After hooking up the delivery hose, visually inspect the connections.
6. If any leakage is discovered during or after delivery, discontinue use and repair or replace.

Filling and Disconnecting

1. Connect the delivery nozzle equipped with the appropriate coupler to the fill adapter and ensure secure connection.
2. Follow pump and meter OEM procedures.
3. Turn on the pumping system.
4. Slowly open the fill nozzle and start product transfer.
5. Always monitor the tank liquid level and the filling process.
6. Look for quick jerk of delivery hose caused by hydraulic shock that indicates the valve shut off has occurred.
7. Close the nozzle after the valve shut off occurred.
8. Turn off the pumping system.
9. Reopen the nozzle and wait for approximately 5 minutes to allow pressure in the line to drop.
10. Close the nozzle and disconnect the coupler.
11. Remove the nozzle and replace the fill connection cap.

See the Manufactures' Limited Warranty Statement

4

3

2

1

REVISIONS				
ZONE	REV.	DESCRIPTION	DATE	APPROVED

NOTES:

D-1: Distance from bottom of valve body to inside surface of tank (or end of riser pipe, if pipe protrudes into tank). Useful in calculating D-2.

D-2: **MINIMUM 4"** - Distance from bottom of valve body to bottom of diffuser. This distance must be 5.5" or greater to allow for flaring the aluminum tubing.

D-3: **MINIMUM 2"** - Length of thin-wall aluminum **45°** flared tube. Must be 2" or greater to allow the tube to be flared with both tube nuts in place.

D-4: **MINIMUM 0.5"** - Distance between edge of diffuser and inside surface of tank wall (or pipe, if pipe protrudes into tank).

D-5: Distance between bottom of diffuser and fill level at shut-off. This will be between approximately 1" and 1.5", depending on density of fuel.

IMPORTANT: Calculations are a starting point only. Physical measurements and adjustments may be required.

Installation:

- Loosely thread valve body onto riser. Measure distance from bottom of valve body to tank wall. Add thickness of tank wall to get D-1.
- Add at least 1/2" to D-1 to get D-2. D-2 must be at least 4".
- Subtract 2" from D-2 to get an approximate value for D-3, the length of the flared tube.
- Cut and flare tubing. It is a good idea to cut the tubing long and dry fit the assembly, then trim to the desired length. **WHEN FLARING TUBE:** After flaring one end, make sure to put on both tube nuts in the orientations shown, as the second flare will prevent you from sliding the nuts on.
- Assemble the valve and tighten tube fittings.
- Attach valve to tank.

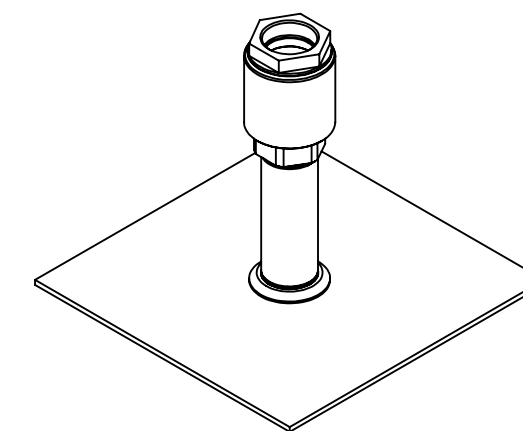
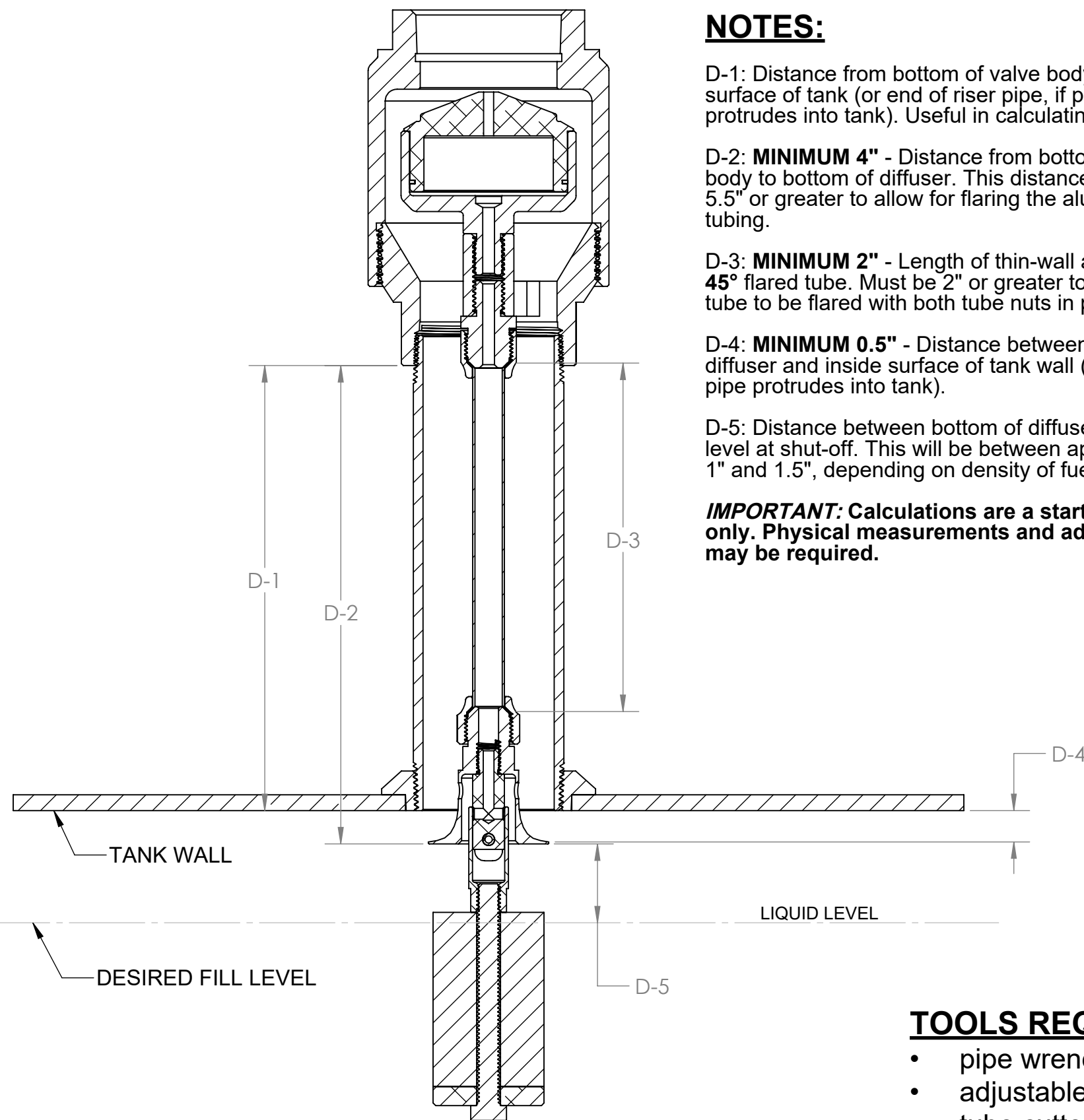

TOOLS REQUIRED:

- pipe wrench
- adjustable wrench
- tube cutter
- 45° tube flaring tool

UNLESS OTHERWISE SPECIFIED:
DIMENSIONS ARE IN INCHES
TOLERANCES:
.X +/- 0.100
.XX +/- 0.030
.XXX +/- 0.010
.XXXX +/- .0005
ANGLES +/- 0.5

APPROVALS	DATE
DRAWN: JJM	13MAY2025
CHECKED: BB	13MAY2025
APPROVED: BB	13MAY2025

MATERIAL:

CLAY & BAILEY MFG. CO.

THIS DRAWING AND CONCEPTS DISCLOSED THEREON BELONG EXCLUSIVELY TO CLAY & BAILEY WHOSE PROPRIETARY RIGHTS THEREIN SHALL NOT BE APPROPRIATED IN WHOLE OR IN PART WITHOUT WRITTEN CONSENT.

TITLE:

GenX 2" OPV Installation Instructions

DWG. NO.:

SIZE: B

SCALE: 1:2

SHEET 1 OF 1

THIRD ANGLE PROJECTION



REV:

SECTION A-A

4

3

2

1