

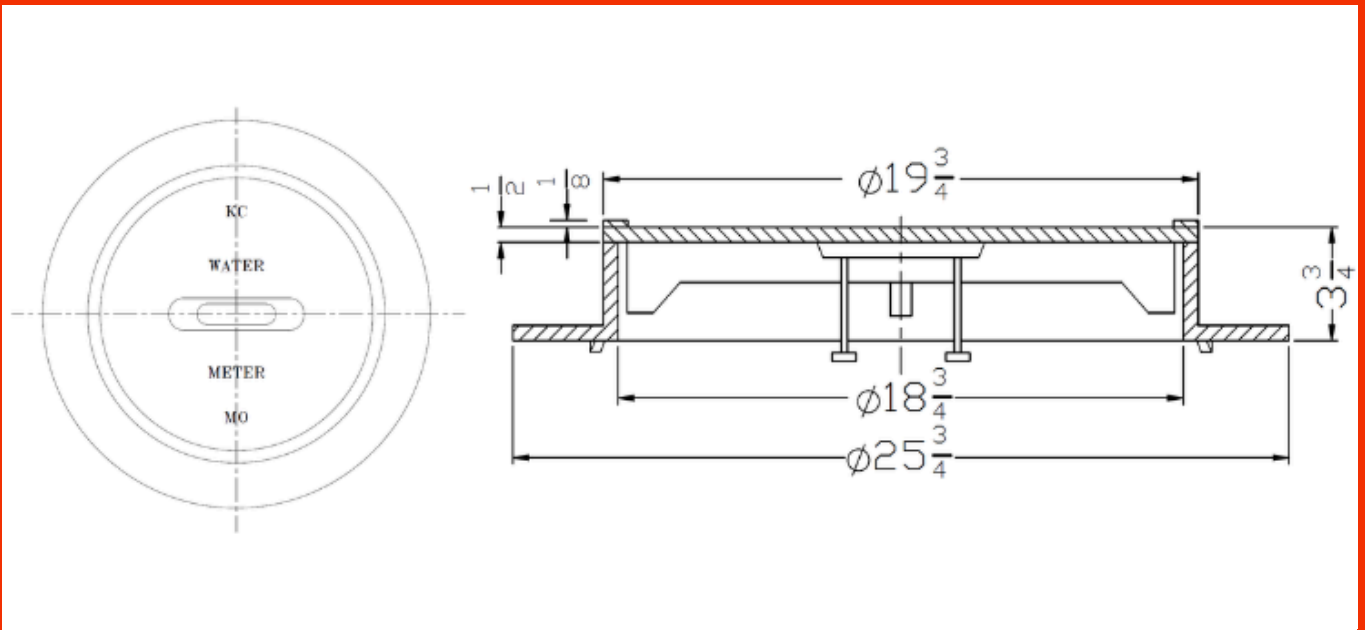

CLAY & BAILEY
MANUFACTURING COMPANY

2209 24" METER COVER



Features:

The 2209 Meter Cover is for use with a 24" nominal meter pit.

Part Number Variations:

02209-01-6001 Foreign Lid w/ Handle
02209-01-6050 Foreign Ring

The lid features a handle for easy access.

We currently only stock Foreign castings.

Please see our plastic lid listing for options other than cast iron.

Revision Date: 3/9/26

Weights
Lid 37 Lbs.
Ring 53 Lbs.

Material Spec:
ASTM A48, CLASS 35B, GRAY IRON



www.claybailey.com



sales@claybailey.com



[1-800-821-6583](tel:1-800-821-6583)