

**PLAN**

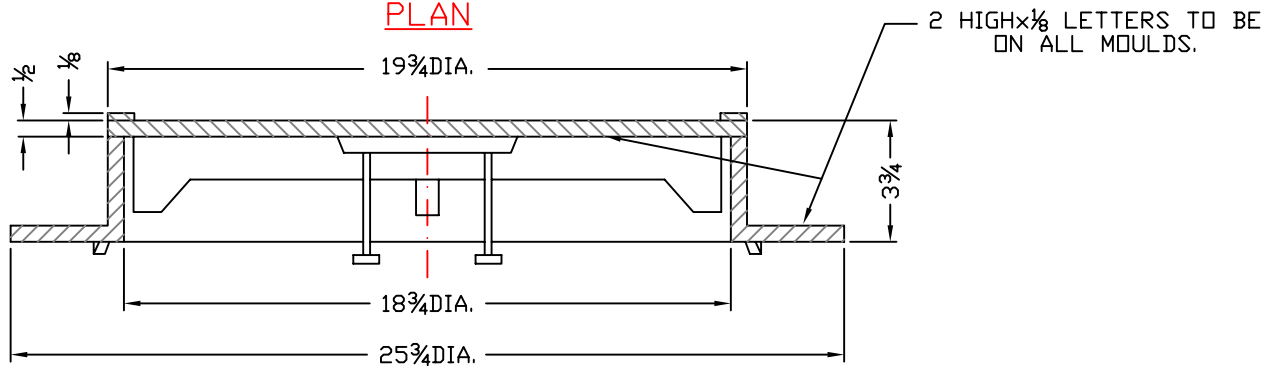

**SECTION-X-X**

RV.NO	REVISION	DATE	RV. BY.	APPR.

**R. B. AGARWALLA & Co.**

2/6, SARAT BOSE ROAD, CALCUTTA-20, INDIA

TITLE:

**C.I. METER BOX LID & FRAME (W-1875)**

DRAWN BY :- P.BHOWMIK      DATE :- 6.12.86

APPROVED BY :- BNA      DRG. NO.:- N3810

DIMENSION:- All are in inches	MARKING:- Lettering for specification will be cast on top of the cover as per requirement.	MATERIAL:- ASTM A48 Class 30.
FINISH:- Coating will be black bituminous paint	MACHINING:- All seating surface will be machined.	