



1700

Part No.	Size	Pr.	Vac.	Wt./Lbs.
1700-03-2400	24"	2 oz.	0.4	65 lbs.

Features

Pressure/Vacuum Relief Manway designed for use on storage tanks that require both pressure/vacuum relief and access. Standard pressure setting is 2 oz. Standard vacuum setting is 0.4 oz. Other pressure and vacuum settings available. Access to the storage tank is through the 24" diameter base after

releasing the quick opening, "Ball in Socket" design cams and raising the cover assembly. Materials of construction include aluminum, ss springs and rods with white nitrile gaskets.

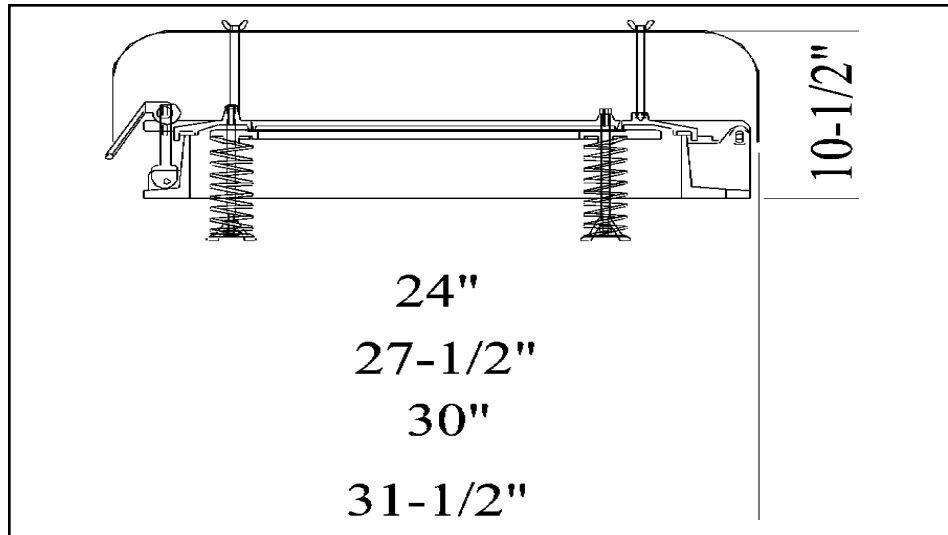

Product Description

The C&B No. 1700 24" PV Manhole is designed for use on storage tanks that require large volume pressure and vacuum relief.

The C&B No. 1700 24" PV Manhole is not a static tank appurtenance, but is an integral part of the dynamic operation of the tank. Just as other pertinent equipment to your process, such as blowers, pumps, and valves, this PV manhold requires a regular maintenance schedule of inspections.

Frequency of Inspections

Frequency of Inspections of No. 1700 Manway are dependent upon the environment and operating conditions.

Definitions

Mild operating conditions - Vented vapors or combination of internal fluids and outside air causes no residue to form, or excessive corrosion on working parts of manway. And/or vapor or gas moving through the manway is constant and no surge shock is encountered.

Extreme operating conditions - Internal vapor, particulate or liquid under operating conditions will cause product buildup or corrosion of manway. Pressure or vacuum surges and shock occurs on a regular basis during operation.

Operating Conditions	No. Insp./Month
Normal	1
Extenuated	2-4*

*Depending on rate of build up or severity of conditions.

1700 Parts Listing

Part Number	Description	Qty.	Part Number	Description	Qty.
A 1	1700-03-0002 Base Ring	1	M 13	1700-10-0014 Jaw End Fitting 3/8" x 6 Galv.	6
B 2	1700-03-0001 Cover	1	N 14	1700-03-0006 Alum. Cam Handle	6
C 3	1700-03-1803 Pressure Disc	1	O 15	1700-02-8001 Cam Swivel Nut	6
D 4	1700-03-0004 Vacuum Disc	1	P 16	1700-03-0017 Dome	1
E 5	1700-05-1800 Pressure/Vacuum Gasket	1	Q 17	1700-07-0008 SST Dome Support Rod 4	
F 6	1700-05-1801 Lid Gasket (See "B" Size Chart)	1	R 18	1700-02-0001 Wing Nut 5/16" - 18 Thd. ZN Pltd.	4
G 7	*0056-07-08XX Pressure Spring (See Chart)	4/8	S 19	0052-17-0001 Tinnerman Cup Nut	2
H 8	*0056-07-08XX Vacuum Spring (See Chart)	4	T 20	1700-07-0007 SST Spring Rod	A/R
I 9	1700-03-1012 Spring Retainer	A/R	U 21	Nameplate Alum.	1
J 10	NYLock Nut 5/16" - 18 A/R		V 22	0395-17-2005 Drive Screw 1/8 x 1/2	4
K 11	1700-07-0011 SST Hinge Pin 3/8" x 9 1/2" lg.	1	W 23	Warning Decal	1
L 12	5/16" Bolt & Lock Nut w/Item 13 Galv.	6	X 24	1700-07-0002 5/16" SST Washer	4

