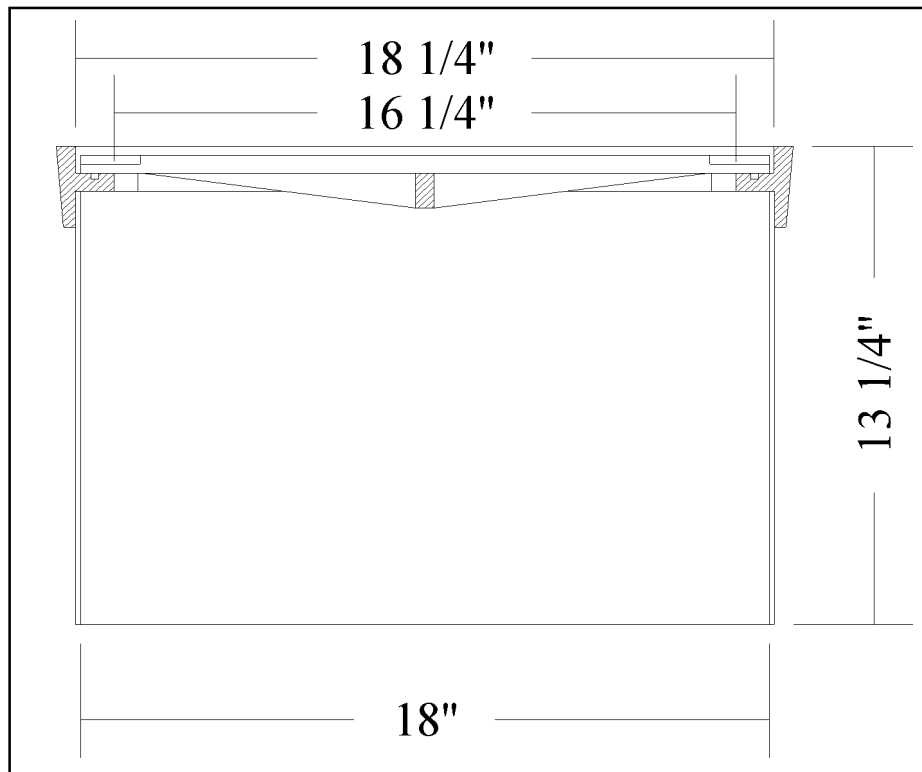

# MONITORING WELL

Part No.	Size	Wt. lbs
1226-01-1800	18"	66

## Features

Large access monitoring well designed for heavy duty usage. Rated for H-20 traffic loads. Standard with O-Ring for a water-resistant seal and mild steel skirt height of 12". Options available are bolted lid for security, other embossing of lids and various collar heights.

**1226**

# MONITORING WELL



**1226**

## Features

Unique design - diamond shaped lid - provides a distinctive look that clearly distinguishes it from standard monitoring wells. Meets the API RP 1615 and provides a full 12" opening. Unit is heavy duty, rated for traffic, with a non-skid surface and bolts for security. Skirt is mild steel and can be fabricated in a variety of heights.

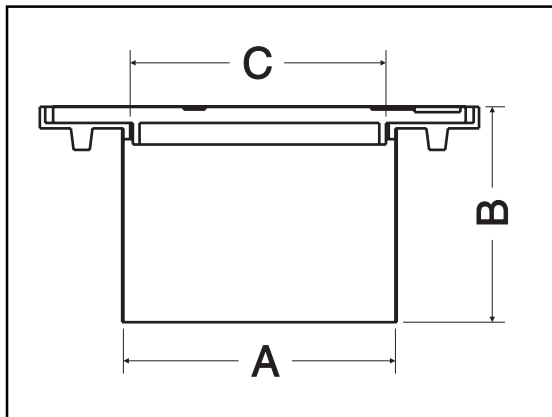

Part No.	Size	Wt. lbs
1226-01-1000	12"	57

A	B	C
13"	10"	12"

